

DRIVE MOTION LITHIUM DATA SHEET



LFP12.8V80AH (24)



Electrical Specifications

Nominal Voltage	12.8 V
Nominal Capacity	80 Ah
Energy	1024 Wh
Self Discharge	≈3% per month
Efficiency	>98%
Parallel Support	Yes, Max 2 Sets
Series Support	Yes, Max 4 Sets

Discharge Specifications

Max. Discharge Current	80 A
End of Discharge Voltage	11.2 V
Pulse Discharge Current	150 A @ 10s
Low Voltage Disconnect	10 V
Low Voltage Reconnect	11.2 V

Charge Specifications

Charging Voltage	14.6 V
Max. Charging Current	80 A
Recommended Charging Current	10 A - 40 A
High Voltage Disconnect	14.8 V
High Voltage Reconnect	13.8 V

Temperature Specifications

Discharge Temperature	-20°C - +55°C (-4°F - +131°F)
Charge Temperature	0°C - +55°C (32°F - +131°F)
Storage Temperature	-10°C - +45°C (14°F - +113°F)
High Temperature Disconnect	+75°C (+167°F)
High Temperature Reconnect	+70°C (+158°F)
Low Temperature Disconnect	-20°C (-4°F)
Low Temperature Reconnect	-15°C (5°F)

Dimensional Specifications

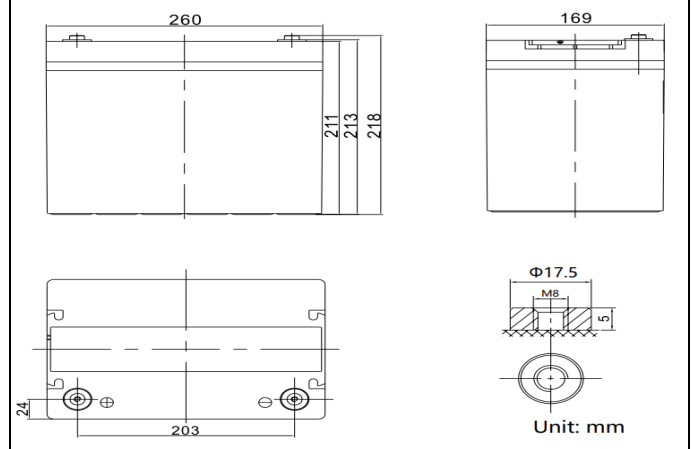

Mechanical Specifications

Dimensions (Group 24)	260 x 168 x 211 10.24 x 6.62 x 8.31
Weight	10 Kg (22.05 lbs)
Terminal Type	M8
Terminal Torque	3.9N/m
Enclosure Protection	IP65

Conception & Compliance

Conception	4S2P
Cell Type	Grade A Prismatic LiFePO4 cells (40Ah)
Certifications	UN38.3 & CE (battery), UL1642 (cells)
Shipping Classification	UN 3480, CLASS 9

DRIVE MOTION LITHIUM DATA SHEET



**Charge Voltage & State of Charge (SOC)
0.2C@25°C (77°F)**

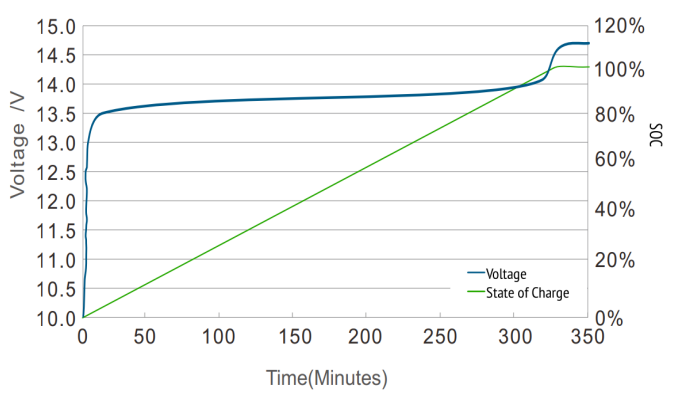

**Discharge Voltage Characteristics at
Various Rates 25°C (77°F)**

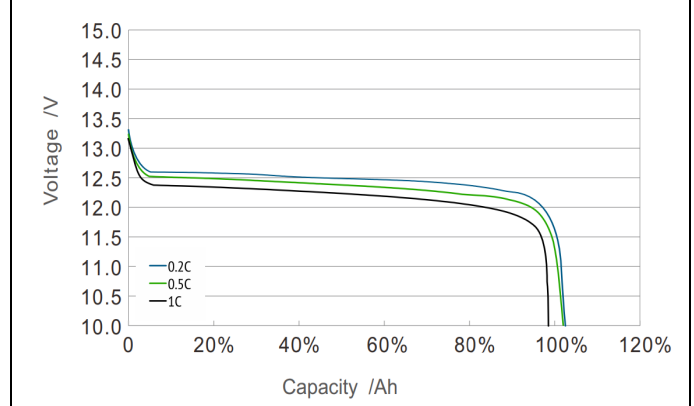

Capacity at Different Temperatures

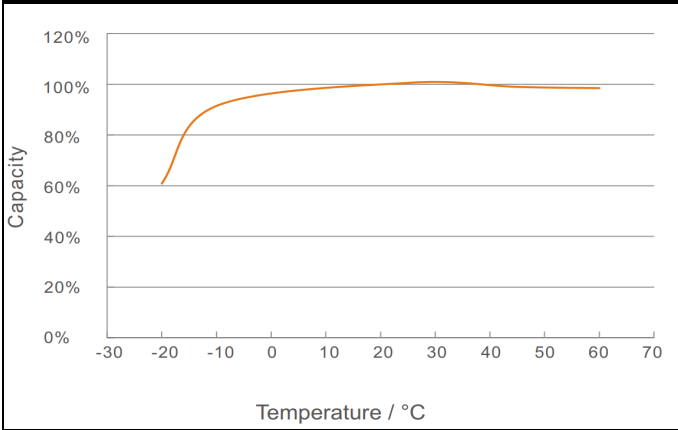

Typical Recharge Time

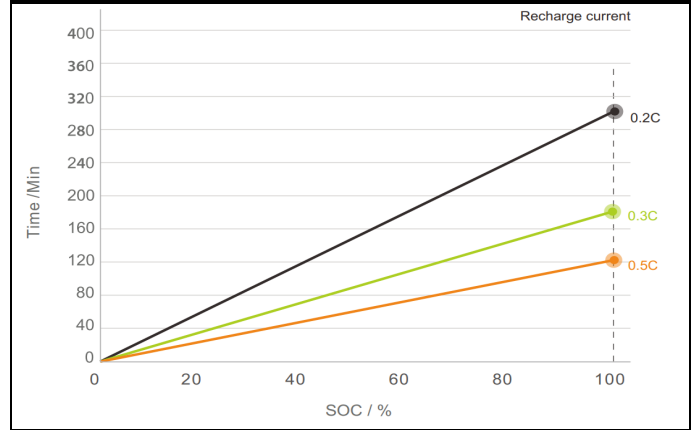

Self Discharge Curve at Different Temperatures

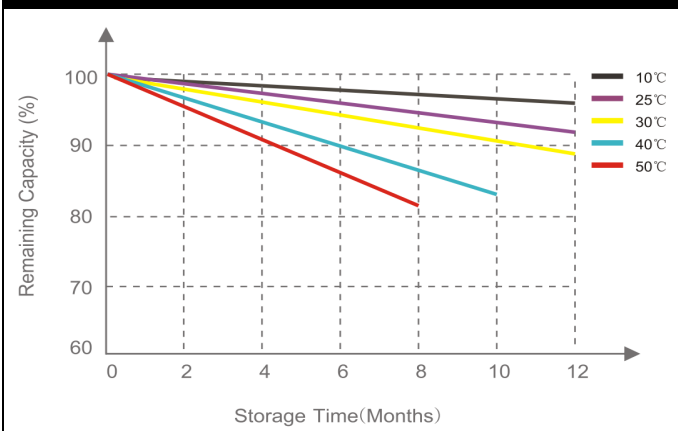

Typical Cycle Life

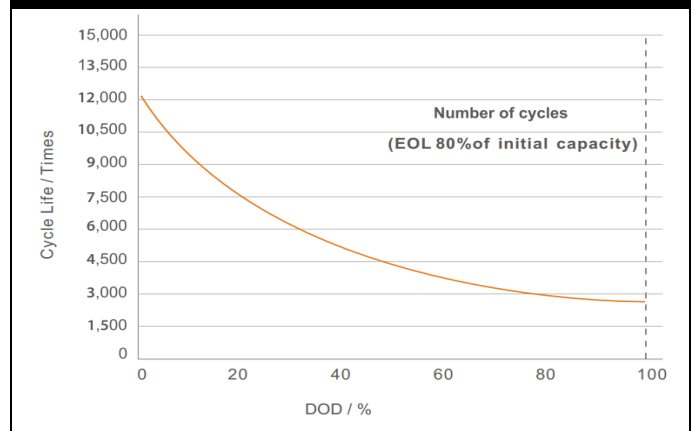

DRIVE MOTION LITHIUM DATA SHEET



Bluetooth App User Guide

Note to user: If the battery receives no charge or is not discharged for over 60 mins, the battery will enter sleep mode. To wake up the battery, simply apply a charge or load and the battery will be visible and ready for pairing in the app.



Download
links

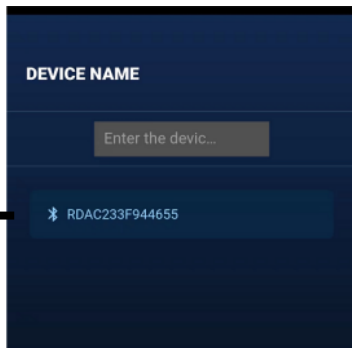

Bluetooth ID

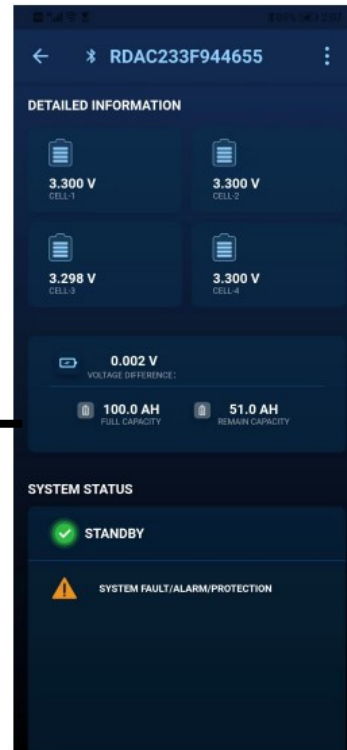

Cell Voltage

Cell Voltage Difference

Rated Capacity

Remaining Capacity



State of Charge

Battery Voltage

Battery Current

Charge & discharge
MOS control status

Rated Capacity

Battery temperature

Number of cycles

Status: Standby,
Charge or Discharge

Alarm & Protection:

- Low temp. alarm
- Low temp. protection
- High temp. alarm
- High temp. protection
- Low voltage alarm
- Low voltage protection
- Over current alarm
- Short current protection